

DRG. No. W33GE000/1
 DRG. REF.

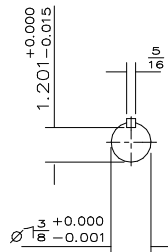

CUSTOMER		
ORDER No.		
PART No.		
OUR ORDER No.		
FRAME SIZE		
KW.	RPM.	
Hz	PHASE	
VOLTS	POLES	
BRGS.	DE.	NDE.
MOTOR NETT WT.	Kg.	
SPECIAL REMARKS		

ALL DIMENSIONS IN INCHES.

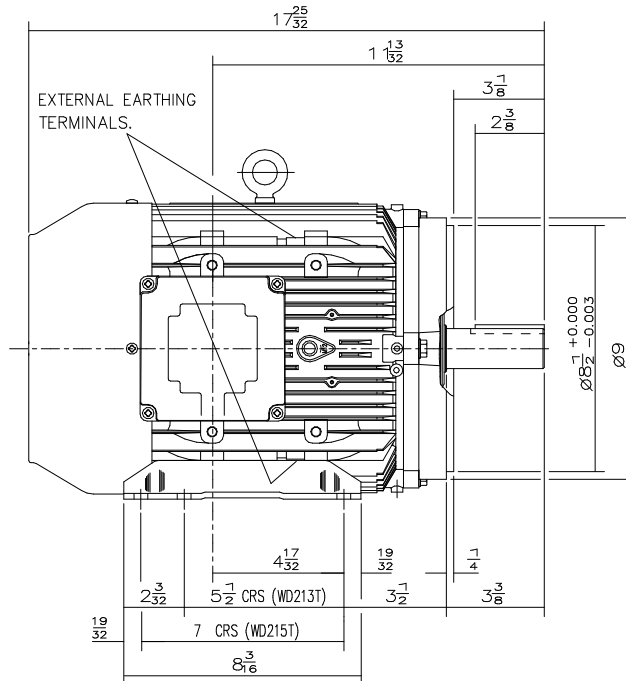
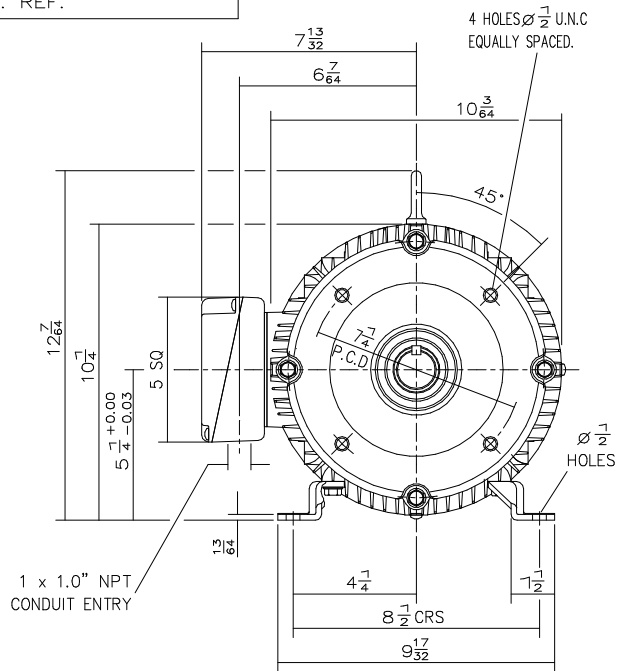
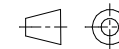

FIRST ANGLE
PROJECTION

**BROOK
CROMPTON**

Huddersfield, HD1 3LJ
ENGLAND

TERMINAL BOX POSITION: - CAN BE ARRANGED EITHER AT 9,12 OR 3 O'CLOCK BY MOVING
STANDARD TERMINAL BOX POSITION IS 9 O'CLOCK AS SHOWN.
CONDUIT ENTRIES: - TERMINAL BOX CAN BE ROTATED AT 90° INTERVALS
(CONDUIT POSITION SHOWN FOR ILLUSTRATION ONLY).

SHEET
SIZE
A3

OUTLINE DIMENSION DRAWING W ALUMINIUM TOTALLY ENCLOSED FAN COOLED
213/5T FRAME FOOT & 'C' INCH FACE MOUNTED MOTORS.

	NAME	DATE
DRAWN	MI	29-08-95
CHECKED	JWD	29-08-95
SCALE	1 : 4	

DRG. No.	W33GE000/1		
DRG. REF.			
REVISION:	DH	DATE	07-07-01